

Lifting Capacities

Telescopic Boom Rough Terrain Crane

RTC-8040

40-ton (36.28 metric ton)

Series II

Boom and Fly Capacities for this machine are listed by the following sections.

Fully Extended Outriggers

- Working Range Diagram
- 33' – 57' (10.05 – 17.37 m) Main Boom Capacities, "A-max" Mode
- 33' – 105' (10.05 – 32.00 m) Main Boom Capacities, Basic Mode "B"
- 28.5' (8.69 m) One-piece Fly Capacities, Basic Mode "B"
- 28.5' – 51' (8.69 – 15.54 m) Two-piece Fly Capacities, Basic Mode "B"

On Tires

- Working Range Diagram
- 33' to 57' (10.05 – 17.37 m) Main Boom Capacities, "A-max" Mode
- 33' to 70' (10.05 – 21.34 m) Main Boom Capacities, Basic Mode "B"

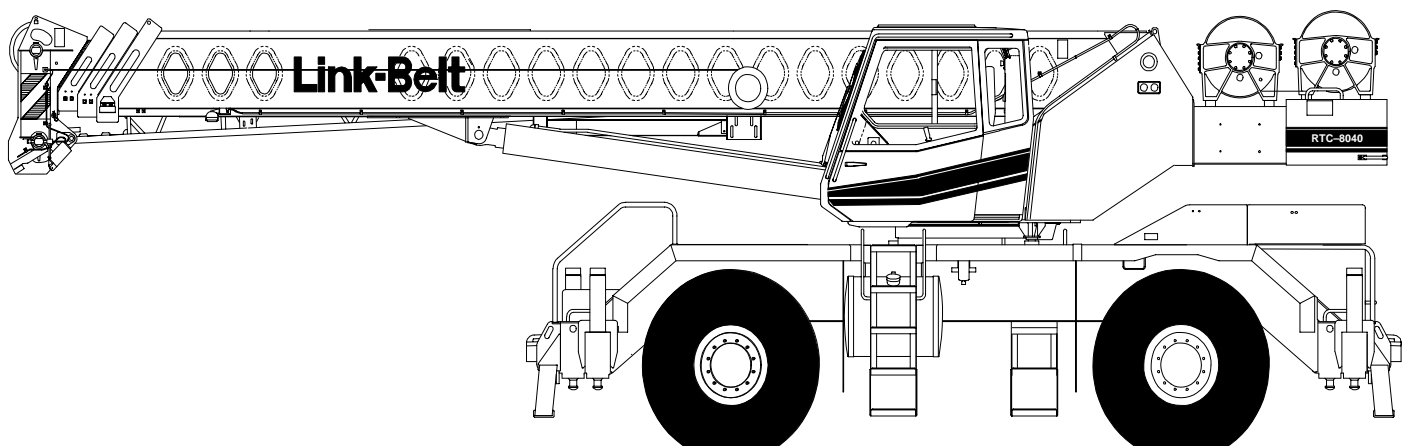

CAUTION: This material is supplied for reference use only. Operator must refer to in-cab Crane Rating Manual to determine allowable machine lifting capacities and operating procedures.

 **WARNING**

READ AND UNDERSTAND THE OPERATOR'S AND SAFETY MANUALS AND THE FOLLOWING INSTRUCTIONS AND RATED LIFTING CAPACITIES BEFORE OPERATING CRANE. OPERATION WHICH DOES NOT FOLLOW THESE INSTRUCTIONS MAY RESULT IN AN ACCIDENT

OPERATING INSTRUCTIONS

GENERAL:

1. Rated lifting capacities in pounds as shown on lift charts pertain to this crane as originally manufactured and normally equipped. Modifications to the crane or use of optional equipment other than that specified can result in a reduction of capacity.
2. Construction equipment can be dangerous if improperly operated or maintained. Operation and maintenance of this crane must be in compliance with the information in the Operator's, Parts, and Safety Manuals supplied with this crane. If these manuals are missing, order replacements through the distributor.
3. The operator and other personnel associated with this crane shall read and fully understand the latest applicable American National Standards ASME B30.5 safety standards for cranes.
4. The rated lifting capacities are based on crane standing level on firm supporting surface.

SET UP:

1. The crane shall be leveled on a firm supporting surface. Depending on the nature of the supporting surface, it may be necessary to have structural supports under the outrigger pontoons or tires to spread the load to a larger bearing surface.
2. When making lifts on outriggers, all tires must be free of supporting surface. All outrigger beams must be extended to the same length; fully retracted, intermediate extended, or fully extended.
3. When operating on tires over the side, do not exceed 75° maximum boom angle. Loss of backward stability will occur causing a backward tipping condition.
4. When making lifts on tires, they must be inflated to the recommended pressure. (See Operation note 20 and Tire Inflation.)
5. For required parts of line, see Wire Rope Capacity and Winch Performance.
6. Before setting up on intermediate outriggers, retracted outriggers, or tires, refer to Working Range Diagrams and rated lifting capacities to determine allowable crane configurations.

OPERATION:

1. Rated lifting capacities at rated radii shall not be exceeded. Do not tip the crane to determine allowable loads. For concrete bucket operation, weight of bucket and load shall not exceed 80% of rated lifting capacities. For clamshell bucket operation, weight of bucket and bucket contents is restricted to a maximum weight of 6,000 pounds or 80% of rated lifting capacity, whichever is less. For magnet operation, weight of magnet and load is restricted to a maximum weight of 6,000 pounds or 80% of rated lifting capacity, whichever is less. For clamshell and magnet operation, maximum boom length is restricted to 50 feet and the boom angle is restricted to a minimum of 35 degrees. Lifts with any fly erected are prohibited for both clam and magnet operation.
2. Rated lifting capacities shown on fully extended outriggers do not exceed 85% of the tipping loads. Rated lifting capacities shown on intermediate extended or fully retracted outriggers are determined by the formula, rated load = (tipping load - 0.1 X load factor) / 1.25. Rated lifting capacities shown on tires do not exceed 75% of the tipping loads. Tipping loads are determined by SAE crane stability test code J-765.
3. Rated lifting capacities in the shaded areas are based on structural strength or hydraulic limitations and have been tested to meet minimum requirements of SAE J-1063 cantilevered boom crane structures—method of test. Rated lifting capacities in the non-shaded areas are based on stability ratings. Some capacities are limited by a maximum obtainable 78° boom angle.
4. Rated lifting capacities include the weight of hook ball/block, slings, bucket, magnet and auxiliary lifting devices. Their weights must be subtracted from the listed rated capacity to obtain the net load that can be lifted. Rated lifting capacities include the deduct for either fly stowed on the base of the boom. For deducts of either fly erected, but not used, see Capacity Deductions For Auxiliary Load Handling Equipment.
5. Rated lifting capacities are based on freely suspended loads. No attempt shall be made to move a load horizontally on the ground in any direction.
6. Rated lifting capacities are for lift crane service only.
7. Do not operate at radii or boom lengths (minimum or maximum) where capacities are not listed. At these positions, the crane can tip or cause boom failure.

8. The maximum loads that can be telescoped are not definable because of variation in loadings and crane maintenance, but it is permissible to attempt retraction and extension within the limits of the applicable load rating chart.
9. For main boom capacities when either boom length or radius or both are between values listed, proceed as follows:
 - a. For boom lengths not listed, use rating for next longer boom length or next shorter boom length, whichever is smaller.
 - b. For load radii not listed, use rating for next larger radius.
10. The user shall operate at reduced ratings to allow for adverse job conditions, such as: soft or uneven ground, out of level conditions, wind, side loads, pendulum action, jerking or sudden stopping of loads, hazardous conditions, experience of personnel, traveling with loads, electrical wires, etc. Side load on boom or fly is dangerous and shall be avoided.
11. Rated lifting capacities do not account for wind on suspended load or boom. Rated capacities and boom length shall be appropriately reduced as wind velocity approaches 20 mph.
12. When making lifts with auxiliary head machinery, the effective length of the boom increases by 2 feet.
13. Power sections of boom must be extended in accordance with boom mode "A" or "B". In boom mode "B" all power sections must be extended or retracted equally.
14. The least stable rated working area depends on the configuration of the crane set up.
15. Rated lifting capacities are based on correct reeving. Deduction must be made for excessive reeving. Any reeving over minimum required (see Wire Rope Capacity) is considered excessive and must be accounted for when making lifts. Use Working Range Diagram to estimate the extra feet of rope then deduct 1 lb. for each extra foot of wire rope before attempting to lift a load.
16. The loaded boom angle combined with the boom length give only an approximation of the operating radius. The boom angle, before loading, should be greater to account for deflection. For main boom capacities, the loaded boom angle is for reference only. For fly capacities, the load radius is for reference only.
17. For fly capacities with main boom length less than 105 ft. and greater than 80 ft., the rated loads are determined by the boom angle using the 105 ft. boom and fly chart. For angles not shown use the next lower boom angle to determine the rated capacity.
18. For fly capacities with main boom length less than 80 ft. the rated loads are determined by the boom angle only using the 80 ft. boom and fly chart. For angles not shown, use the next lower boom angle to determine the rated capacity.
19. The 33 ft. boom length structural capacities are based on boom fully retracted. If the boom is not fully retracted, do not exceed capacities shown for the 40 ft. boom length.
20. Rated lifting capacities on tires depend on tire capacity, condition of tires, and tire air pressure. On tire capacities require lifting from main boom head only on a smooth and level surface. Pick and carry operations are restricted to speed of 2.5 mph and creep. The boom must be centered over the front of the crane with two-position travel swing lock engaged and the load must be restrained from swinging. Lifts with any fly erected on tires are prohibited. For correct tire pressure, see Tire Inflation.

DEFINITIONS:

1. Load Radius: Horizontal distance from a projection of the axis of rotation to the supporting surface, before loading, to the center of the vertical hoist line or tackle with load applied.
2. Loaded Boom Angle: \angle° The angle between the boom base section and horizontal with freely suspended load at the rated radius.
3. Working Area: Area measured in a circular arc about the center line of rotation as shown on the Working Area Diagram.
4. Freely Suspended Load: Load hanging free with no direct external force applied except by the hoist line.
5. Side Load: Horizontal side force applied to the lifted load either on the ground or in the air.
6. No Load Stability Limit: The radius or boom angle beyond which it is not permitted to position the boom because the crane can overturn without any load on the hook.
7. Load Factor: Load applied at the boom tip which gives the same moment effect as the boom mass.

TIRE INFLATION

Tire Size	Operation	Tire Pressure (psi)
23.5 x 25 – 20 Ply Rating	1 mph Stationary	80 80

PONTOON LOADINGS

Maximum Pontoon Load	Maximum Pontoon Ground Bearing Pressure:
63,500 lb	213 psi

BOOM MODES

Boom Mode “A”
Only inner mid section telescopes.

Boom Length (Ft.)

33
40
50
57

Inner Mid Section 288” Stroke Base Section

Boom Mode “B”
Inner–mid, outer–mid and tip sections telescope simultaneously.

Boom Length (Ft.)

33
40
50
60
70
80
90
105

Tip Section 288” Stroke Outer Mid Section 288” Stroke Inner Mid Section 288” Stroke Base Section

WIND SPEED RESTRICTIONS

If The Wind Speed Exceeds:	Rated Lifted Capacities Must Be Reduced By At Least:
20 MPH	40%
30 MPH	70%
40 MPH	Crane operation must be shutdown and the boom retracted and lowered to horizontal.

- Additional reductions are required for loads with large wind sail area.
- These restrictions are based on machine on fully extended outriggers.
- The operator shall add 10° to all minimum boom angles due to no load stability and shall not boom down below that angle.

WINCH PERFORMANCE

Wire Rope Layer	Winch Line Pulls		Drum Rope Capacity (Ft.)	
	Two Speed Winch		Layer	Total
	Low Speed Available Lbs.*	High Speed Available Lbs.		
1	15,390	7,302	114	114
2	14,150	6,714	124	238
3	13,094	6,213	134	372
4	12,185	5,781	144	516
5	11,394	5,406	154	670

* Maximum lifting capacity:
Type RB Rope = 12,920 Type ZB Rope = 15,600

WIRE ROPE CAPACITY

Maximum Lifting Capacities Based On Wire Rope Strength			
Parts of Line	3/4”	3/4”	Notes
	Type RB	Type ZB	
1	12,920	15,600	Capacities shown are in pounds and working loads must not exceed the ratings on the capacity charts in the Crane Rating Manual. Study Operator’s Manual for wire rope inspection procedures and single part of line application.
2	25,840	31,200	
3	38,760	46,800	
4	51,680	62,400	
5	64,600	78,000	
6	77,520	93,600	
7	90,440	109,200	
8	103,360	124,800	
LBCE		DESCRIPTION	
Type RB	18 x 19 Rotation Resistant – Compacted Strand – High Strength, Preformed, Right Regular Lay		
Type ZB	36 x 7 Rotation Resistant – Extra Improved Plow Steel – Right Regular Lay		

HYDRAULIC CIRCUIT PRESSURE SETTINGS

Function	Pressure (psi)
Front And Rear Winch	3,500
Outrigger	3,000
Boom Hoist	3,350
Telescope	3,000
Swing	1,500
Steering	2,500
Pilot Control	500

WORKING AREAS

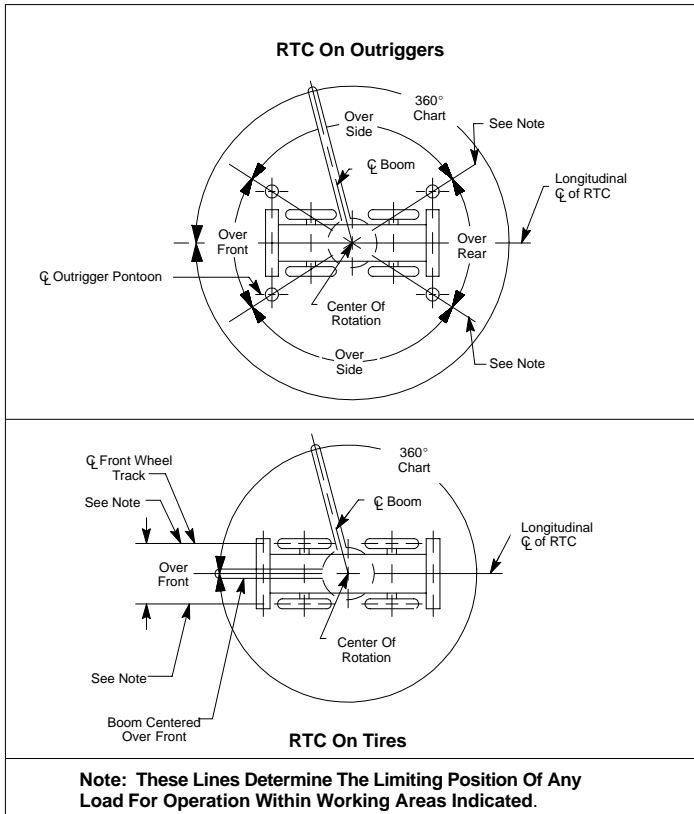

CAPACITY DEDUCTIONS FOR AUXILIARY LOAD HANDLING EQUIPMENT

Load Handling Equipment	Weight (lbs)
Auxiliary Head Attached	100
40 Ton Quick Reeve 4 Sheave Hook Block (See Hook Block For Actual Weight)	720
8.5 Ton Hook Ball (See Hook Ball For Actual Weight)	360

Lifting From Main Boom With:	
28.5 or 51 Ft. Fly Stowed on Boom Base (See operation note #4)	0
28.5 Ft. Offset Fly Erected But Not Used	2,800
51 Ft. Offset Fly Erected But Not Used	5,000

Lifting From 28.5 Ft. Offset Fly With:	
22.5 Ft. Fly Tip Erected But Not Used	PROHIBITED
22.5 Ft. Fly Tip Stowed On 28.5 Ft. Offset Fly	PROHIBITED
Note: Capacity deductions are for Link-Belt supplied equipment only.	

WORKING RANGE DIAGRAM

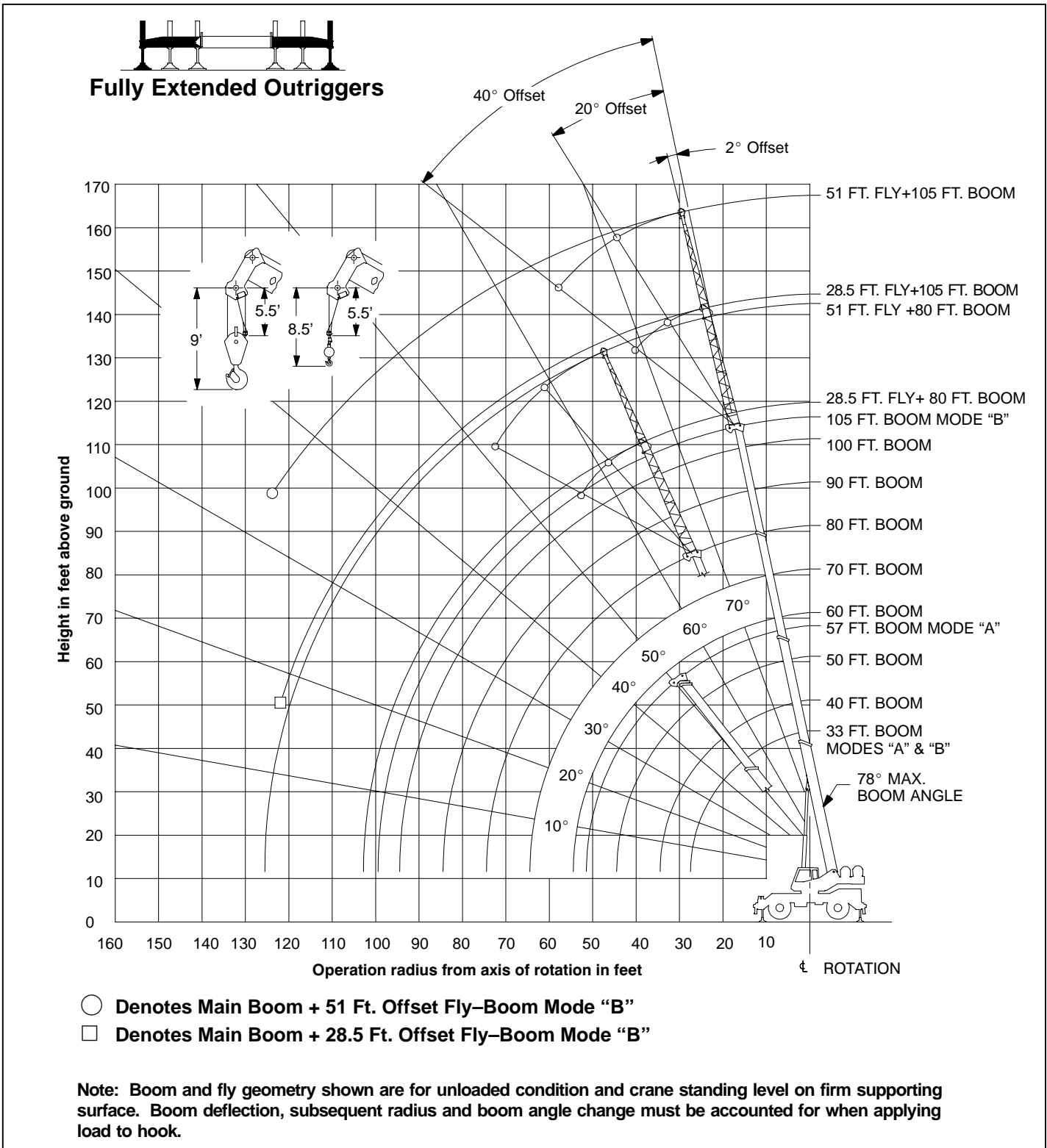

WARNING

Do Not Lower The Boom Below The Minimum Boom Angle For No Load Stability As Shown In The Lift Charts For The Boom Lengths Given. Loss Of Stability Will Occur Causing A Tipping Condition.

Note: Refer To Page 5 For “Capacity Deductions For Auxiliary Load Handling Equipment”. \angle Loaded Boom Angle In Degrees. () Reference Radius For Minimum Boom Angle Capacities (Shown In Parenthesis) Are In Feet.

Rated Lifting Capacities In Pounds
Fully Extended Outriggers
See Set Up Note 2



FULL **MAIN BOOM “A”**

Load Radius (Ft.)	33 Ft.			40 Ft.		
	\angle °	360°	Over Front	\angle °	360°	Over Front
10	66.0	80,000	80,000	70.5	72,100	72,100
12	62.0	73,800	75,200	67.5	72,100	72,100
15	55.5	63,100	64,300	62.5	62,900	64,100
20	43.5	47,300	47,300	54.0	47,100	47,100
25	26.5	36,100	36,100	44.0	35,900	35,900
30				31.0	28,400	28,400
Min. Boom Angle / Cap.	0 (27.5)	20,200	20,200	0 (34.5)	15,600	15,600
Load Radius (Ft.)	50 Ft.			57 Ft.		
	\angle °	360°	Over Front	\angle °	360°	Over Front
10	75.0	70,500	70,500	77.0	43,800	43,800
12	73.0	65,600	65,600	75.0	43,800	43,800
15	69.0	57,400	57,400	72.0	42,200	42,200
20	62.5	46,800	46,800	66.5	34,200	34,200
25	55.5	35,700	35,700	61.0	28,700	28,700
30	48.0	28,200	28,200	54.5	24,500	24,500
35	39.0	22,900	22,900	48.0	21,300	21,300
40	27.5	17,700	18,800	40.0	17,500	18,600
45				30.5	13,800	14,700
50				16.5	11,000	11,800
Min. Boom Angle / Cap.	0 (44.5)	10,400	10,400	0 (51.5)	7,900	7,900

Rated Lifting Capacities In Pounds
Fully Extended Outriggers
See Set Up Note 2



FULL **MAIN BOOM “B”**

Load Radius (Ft.)	33 Ft.			40 Ft.			50 Ft.		
	\angle °	360°	Over Front	\angle °	360°	Over Front	\angle °	360°	Over Front
10	66.0	80,000	80,000	70.5	35,000	35,000	74.5	35,000	35,000
12	62.0	73,800	75,200	67.5	35,000	35,000	72.5	35,000	35,000
15	55.5	63,100	64,300	62.5	35,000	35,000	68.5	35,000	35,000
20	43.5	47,300	47,300	54.0	35,000	35,000	62.5	35,000	35,000
25	26.5	36,100	36,100	44.0	35,000	35,000	55.5	35,000	35,000
30				31.0	29,200	29,200	48.0	29,800	29,800
35							39.0	24,400	24,400
40							27.5	19,500	20,400
MinBm Angle / Cap	0 (27.5)	20,200	20,200	0 (34.5)	15,000	15,000	0 (44.5)	10,300	10,300
Load Radius (Ft.)	60 Ft.			70 Ft.			80 Ft.		
	\angle °	360°	Over Front	\angle °	360°	Over Front	\angle °	360°	Over Front
10	77.5	35,000	35,000						
12	75.5	35,000	35,000						
15	72.5	35,000	35,000	75.5	35,000	35,000			
20	67.5	35,000	35,000	71.5	35,000	35,000	74.5	30,500	30,500
25	62.5	35,000	35,000	67.5	35,000	35,000	71.0	26,300	26,300
30	56.5	30,100	30,100	62.5	30,300	30,300	67.0	22,900	22,900
35	50.5	24,800	24,800	58.0	25,000	25,000	63.0	20,200	20,200
40	43.5	19,800	20,700	52.5	19,900	20,900	58.5	18,000	18,000
45	35.5	15,900	16,900	46.5	16,100	17,100	54.0	16,200	16,200
50	25.0	13,100	13,900	40.5	13,200	14,100	49.0	13,400	14,200
55				33.0	11,100	11,900	44.0	11,200	12,000
60				23.5	9,300	10,000	38.0	9,500	10,200
65							31.0	8,000	8,700
70							22.0	6,800	7,400
MinBm Angle / Cap	0 (54.5)	7,400	7,400	0 (64.5)	5,400	5,400	0 (74.5)	3,900	3,900
Load Radius (Ft.)	90 Ft.			100 Ft.			105 Ft.		
	\angle °	360°	Over Front	\angle °	360°	Over Front	\angle °	360°	Over Front
20	77.0	27,100	27,100						
25	73.5	23,400	23,400	76.0	20,900	20,900	76.5	17,500	17,500
30	70.0	20,400	20,400	73.0	18,600	18,600	74.0	17,500	17,500
35	66.5	18,000	18,000	69.5	16,200	16,200	71.0	15,700	15,700
40	63.0	16,000	16,000	66.5	14,500	14,500	68.0	13,900	13,900
45	59.5	14,300	14,300	63.5	13,000	13,000	65.0	12,200	12,200
50	55.5	13,000	13,000	60.0	11,700	11,700	62.0	10,700	10,700
55	51.0	11,300	11,800	56.5	10,600	10,600	58.5	9,500	9,500
60	46.5	9,600	10,200	53.0	9,600	9,700	55.0	8,400	8,400
65	41.5	8,100	8,700	49.0	8,200	8,800	51.5	7,500	7,500
70	36.0	7,000	7,500	44.5	7,000	7,600	47.5	6,800	6,800
75	29.5	6,000	6,500	40.0	6,000	6,500	43.5	6,000	6,100
80	21.0	5,100	5,600	34.5	5,200	5,600	39.0	5,200	5,500
85				28.5	4,400	4,900	34.0	4,500	4,900
90				20.5	3,800	4,200	28.0	3,800	4,200
95							20.0	3,200	3,600
MinBm Angle / Cap	0 (84.5)	2,800	2,800	0 (94.5)	2,000	2,000	0 (99.5)	1,600	1,600

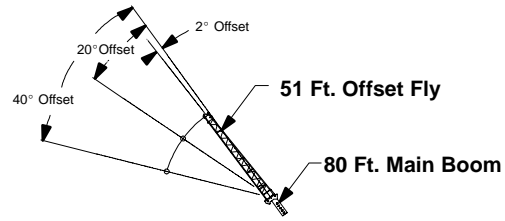
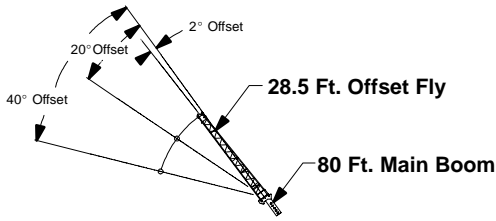

Rated Lifting Capacities In Pounds Fully Extended Outriggers See Set Up Note 2						
Load Radius (Ft.)	FULL					
	2° Offset		20° Offset		40° Offset	
	∠ °	360°	∠ °	360°	∠ °	360°
25	77.0	13,800				
30	74.5	12,800				
35	72.0	11,800	76.0	8,700		
40	69.0	11,000	73.0	8,100	77.0	6,100
45	66.0	10,200	70.0	7,500	74.0	5,800
50	63.0	9,600	67.0	7,100	71.0	5,600
55	60.0	8,900	64.0	6,700	67.5	5,400
60	57.0	8,200	61.0	6,300	64.0	5,200
65	53.5	7,600	57.5	6,000	60.5	5,100
70	50.0	7,100	54.0	5,700	57.0	5,000
75	46.5	6,600	50.0	5,500	52.5	4,900
80	42.0	6,000	46.0	5,300	48.0	4,800
85	37.5	5,300	41.5	5,100	43.0	4,800
90	32.0	4,600	36.0	4,800		
95	26.0	4,000	29.0	4,200		
100	17.0	3,500	19.0	3,600		
Min. Boom Angle / Cap	0	1,700	0	1,800	0	1,900

Rated Lifting Capacities In Pounds Fully Extended Outriggers See Set Up Note 2						
Load Radius (Ft.)	FULL					
	2° Offset		20° Offset		40° Offset	
	∠ °	360°	∠ °	360°	∠ °	360°
35	76.0	7,400				
40	74.0	6,700				
45	71.5	6,100	78.0*	4,200		
50	69.5	5,500	76.0	3,900		
55	67.0	5,100	73.5	3,700		
60	64.5	4,700	71.0	3,400	77.0	2,700
65	62.0	4,300	68.5	3,200	74.5	2,500
70	59.5	4,000	66.0	3,100	72.0	2,500
75	57.0	3,700	63.0	2,900	69.0	2,400
80	54.0	3,500	60.5	2,800	66.0	2,300
85	51.0	3,300	57.5	2,600	62.5	2,200
90	48.0	3,100	54.5	2,500	59.5	2,200
95	45.0	2,900	51.0	2,400	55.5	2,200
100	41.5	2,700	47.5	2,300	51.5	2,100
105	37.5	2,600	43.5	2,300	47.0	2,100
110	33.5	2,400	39.0	2,200	41.5	2,100
115	28.5	2,300	34.0	2,200		
120	22.5	2,200	27.0	2,100		
125	11.0	2,200				
Min.Boom Angle/Cap.	0	900	0	900	0	1,100

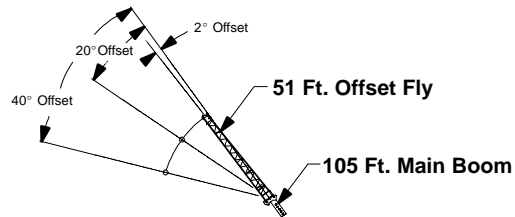
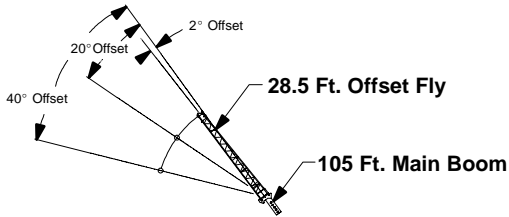

Rated Lifting Capacities In Pounds Fully Extended Outriggers See Set Up Note 2						
Load Radius (Ft.)	FULL					
	2° Offset		20° Offset		40° Offset	
	∠ °	360°	∠ °	360°	∠ °	360°
35	76.5	9,000				
40	74.5	9,000	78.0*	7,900		
45	72.5	8,700	76.0	7,500		
50	70.0	7,900	73.5	7,100	76.5	5,600
55	67.5	7,200	71.0	6,600	74.0	5,500
60	65.5	6,600	69.0	6,100	71.5	5,300
65	63.0	6,100	66.5	5,600	69.5	5,200
70	60.5	5,600	64.0	5,200	66.5	4,900
75	57.5	5,100	61.0	4,900	64.0	4,600
80	55.0	4,600	58.5	4,600	61.0	4,400
85	52.0	4,100	55.5	4,300	58.0	4,100
90	49.0	3,600	52.5	3,800	55.0	3,900
95	45.5	3,300	49.0	3,400	51.5	3,500
100	42.5	2,900	45.5	3,000	47.5	3,100
105	38.5	2,600	41.5	2,700	43.0	2,700
110	34.5	2,300	37.5	2,400		
115	30.0	2,000	32.5	2,100		
120	24.0	1,700	26.5	1,800		

Rated Lifting Capacities In Pounds Fully Extended Outriggers See Set Up Note 2						
Load Radius (Ft.)	FULL					
	2° Offset		20° Offset		40° Offset	
	∠ °	360°	∠ °	360°	∠ °	360°
40	77.5	5,800				
45	76.0	5,700				
50	74.0	5,400				
55	72.0	5,100	77.5	3,700		
60	70.5	4,800	75.5	3,500		
65	68.5	4,500	73.5	3,300		
70	66.5	4,100	71.5	3,200	76.5	2,500
75	64.5	3,800	69.5	3,000	74.5	2,400
80	62.5	3,500	67.5	2,900	72.5	2,300
85	60.0	3,300	65.5	2,800	70.5	2,300
90	58.0	3,000	63.5	2,700	68.0	2,200
95	55.5	2,700	61.0	2,600	65.5	2,200
100	53.0	2,400	58.5	2,400	63.0	2,100
105	50.5	2,200	56.0	2,200	60.5	2,100
110	47.5	1,900	53.5	2,000	57.5	2,000
115	45.0	1,600	50.5	1,800	54.5	1,800
120	42.0	1,400	47.5	1,600	51.0	1,700
125	39.0	1,200	44.0	1,300	47.0	1,400
130	35.5	1,000	40.5	1,100	42.0	800
135			36.5	1,000		

WARNING
Do Not Lower 28.5 Ft. Offset Fly In Working Position Below 17° Main Boom Angle Unless Main Boom Length Is 102 Ft. Or Less, Since Loss Of Stability Will Occur Causing A Tipping Condition.

WARNING
Do Not Lower 51 Ft. Offset Fly In Working Position Below 34° Main Boom Angle Unless Main Boom Length Is 92 Ft. Or Less, Since Loss Of Stability Will Occur Causing A Tipping Condition.

WORKING RANGE DIAGRAM

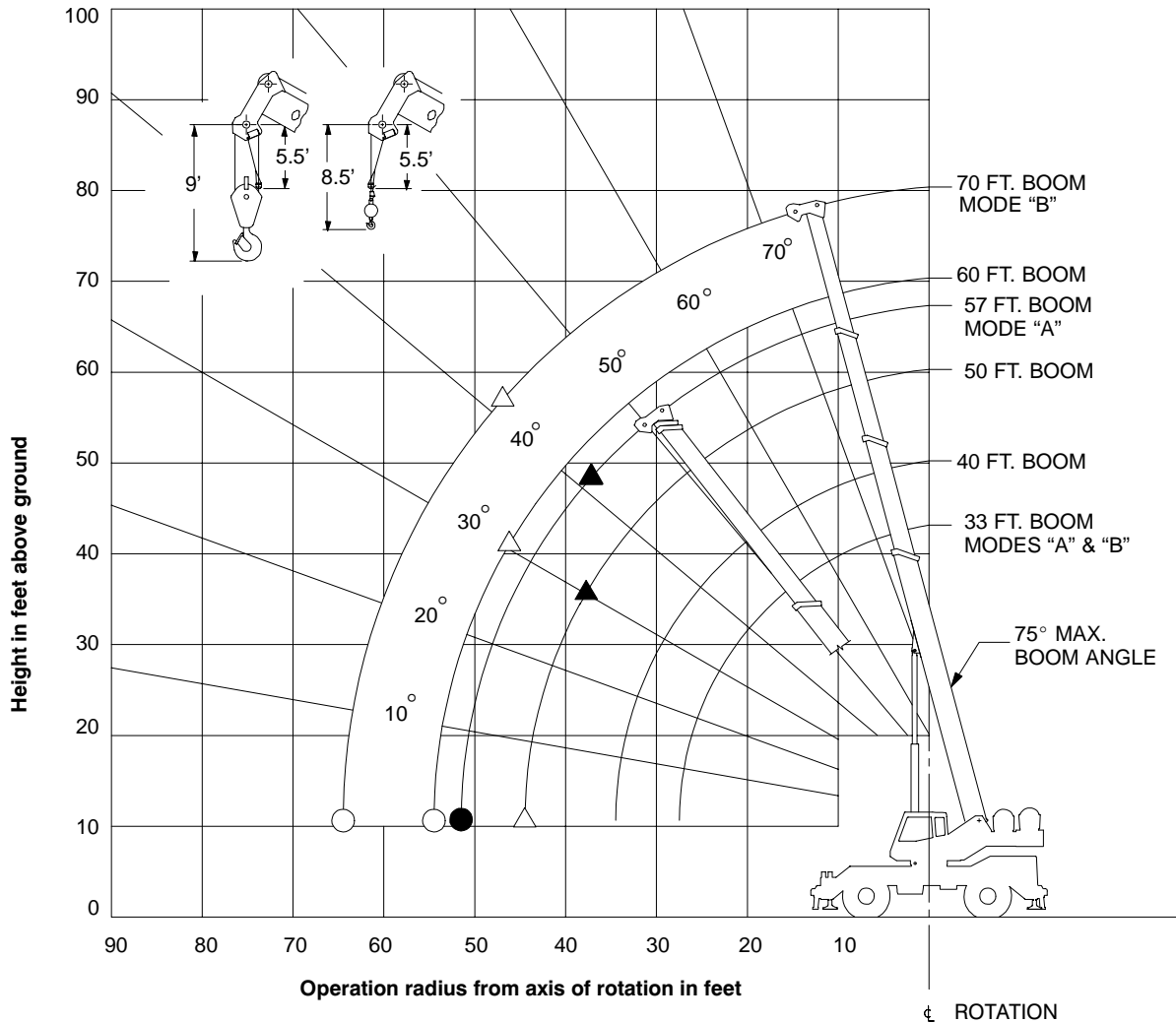

Crane Configurations Prohibited:
 Boom Lengths Greater than 70 FT.
 28.5 FT. Offset Fly
 51 FT. Offset Fly

- ▲ Denotes Main Boom 360° – Boom Mode "A"
- △ Denotes Main Boom 360° – Boom Mode "B"
- Denotes Main Boom Between Tire Tracks Or Centered Over Front – Boom Mode "A"
- Denotes Main Boom Between Tire Tracks Or Centered Over Front – Boom Mode "B"

Note: Boom geometry shown is for unloaded condition and crane standing level on firm supporting surface. Boom deflection, subsequent radius and boom angle change must be accounted for when applying load to hook.

WARNING

Do Not Lower The Boom Below The Minimum Boom Angle For No Load Stability Or Raise Boom Above 75° As Shown In The Lift Charts For The Boom Lengths Given. Loss Of Stability Will Occur Causing A Tipping Condition.

On Tire Capacities In Pounds
Tire Pressure: See Page 5

ON TIRES

Stationary Capacities
Over Front Between Tire Tracks
See Operation Note 20

MAIN BOOM "A"

Load Radius (Ft.)	33 Ft.		40 Ft.	
	∠ °	Load	∠ °	Load
10	66.0	46,200	70.5	45,900
12	62.0	40,700	67.5	40,400
15	55.5	34,500	62.5	34,200
20	43.5	27,100	54.0	26,900
25	26.5	20,100	43.5	19,900
30			31.0	14,100
Min.Boom Angle/Cap.	0 (27.5)	16,600	0 (34.5)	10,500
Load Radius (Ft.)	50 Ft.		57 Ft.	
	∠ °	Load	∠ °	Load
15	69.0	34,000		
20	62.5	26,600	66.5	26,500
25	55.5	19,600	60.5	19,400
30	47.5	13,900	54.5	13,700
35	39.0	10,200	47.5	10,100
40	27.5	7,500	40.0	7,500
45			30.5	5,600
50			16.0	4,000
Min.Boom Angle/Cap.	0 (44.5)	5,700	0 (51.5)	3,600

On Tire Capacities In Pounds
Tire Pressure: See Page 5

ON TIRES

Pick & Carry Capacities
(1 MPH) Boom Centered Over Front.
See Operation Note 20

MAIN BOOM "A"

Load Radius (Ft.)	33 Ft.		40 Ft.	
	∠ °	Load	∠ °	Load
10	66.0	43,800	70.5	43,500
12	62.0	38,200	67.5	37,900
15	55.5	31,600	62.5	31,400
20	43.5	24,000	53.5	23,800
25	26.5	18,700	43.5	18,500
30			31.0	14,100
Min.Boom Angle/Cap.	0 (27.5)	16,500	0 (34.5)	10,500
Load Radius (Ft.)	50 Ft.		57 Ft.	
	∠ °	Load	∠ °	Load
15	68.5	31,200		
20	62.5	23,600	66.5	23,500
25	55.5	18,400	60.5	18,300
30	47.5	13,900	54.5	13,700
35	39.0	10,200	47.5	10,100
40	27.5	7,500	40.0	7,500
45			30.5	5,600
50			16.0	4,000
Min.Boom Angle/Cap.	0 (44.5)	5,700	0 (51.5)	3,600

On Tire Capacities In Pounds
Tire Pressure: See Page 5

ON TIRES

Stationary Capacities
Over Front Between Tire Tracks
See Operation Note 20

MAIN BOOM "B"

Load Radius (Ft.)	33 Ft.		40 Ft.		50 Ft.	
	∠ °	Load	∠ °	Load	∠ °	Load
10	66.0	46,200	70.5	35,000		
12	62.0	40,700	67.5	35,000	72.5	35,000
15	55.5	34,500	62.5	34,900	68.5	35,000
20	43.5	27,100	53.5	27,500	62.0	27,900
25	26.5	20,100	43.5	20,800	55.0	21,200
30			31.0	14,800	47.5	15,400
35					38.5	11,600
40					27.5	8,900
Min.Boom Angle/Cap.	0 (27.5)	16,600	0 (34.5)	11,300	0 (44.5)	7,100
Load Radius (Ft.)	60 Ft.		70 Ft.			
	∠ °	Load	∠ °	Load		
20	67.5	28,200				
25	62.0	21,400	67.0	21,600		
30	56.5	15,600	62.0	15,800		
35	50.0	11,900	57.0	12,100		
40	43.0	9,300	52.0	9,500		
45	35.0	7,300	46.0	7,500		
50	25.0	5,800	40.0	6,000		
55			32.5	4,800		
60			23.0	3,800		
Min.Boom Angle/Cap.	0 (54.5)	4,600	0 (64.5)	3,000		

On Tire Capacities In Pounds
Tire Pressure: See Page 5

ON TIRES

Pick & Carry Capacities
(1 MPH) Boom Centered Over Front.
See Operation Note 20

MAIN BOOM "B"

Load Radius (Ft.)	33 Ft.		40 Ft.		50 Ft.	
	∠ °	Load	∠ °	Load	∠ °	Load
10	66.0	43,800	70.5	35,000		
12	62.0	38,200	67.5	35,000	72.5	35,000
15	55.5	31,600	62.5	32,000	68.5	32,300
20	43.5	24,000	53.5	24,400	62.0	24,800
25	26.5	18,700	43.5	19,200	55.0	19,600
30			31.0	14,800	47.5	15,400
35					38.5	11,600
40					27.5	8,900
Min.Boom Angle/Cap.	0 (27.5)	16,500	0 (34.5)	11,300	0 (44.5)	7,100
Load Radius (Ft.)	60 Ft.		70 Ft.			
	∠ °	Load	∠ °	Load		
20	67.5	25,000				
25	62.0	19,900	67.0	20,000		
30	56.5	15,600	62.0	15,800		
35	50.0	11,900	57.0	12,100		
40	43.0	9,300	52.0	9,500		
45	35.0	7,300	46.0	7,500		
50	25.0	5,800	40.0	6,000		
55			32.5	4,800		
60			23.0	3,800		
Min.Boom Angle/Cap.	0 (54.5)	4,600	0 (64.5)	3,000		

On Tire Capacities In Pounds
Tire Pressure: See Page 5

Stationary Capacities – 360 Degree
See Operation Note 20

360°

ON TIRES

MAIN BOOM "A"

Load Radius (Ft.)	33 Ft.		40 Ft.	
	∠ °	Load	∠ °	Load
10	66.0	35,900	70.5	35,600
12	62.0	30,100	67.5	29,800
15	55.5	21,500	62.5	21,200
20	43.5	12,800	53.5	12,700
25	26.5	8,200	43.5	8,100
30			31.0	5,200
Min.Boom Angle/Cap.	0 (27.5)	6,400	0 (34.5)	3,300
Load Radius (Ft.)	50 Ft.		57 Ft.	
	∠ °	Load	∠ °	Load
15	68.5	20,700		
20	62.0	12,400	66.0	12,200
25	55.0	7,900	60.0	7,800
30	47.5	5,100	54.0	5,000
35	38.5	3,100	47.0	3,000
Min.Boom Angle/Cap.	30.0 (38.9)		41.5 (38.6)	

⚠ WARNING
Do Not Raise Boom Above 75° Boom Angle.
Loss Of Backward Stability Will Occur Causing a Tipping Condition.

On Tire Capacities In Pounds
Tire Pressure: See Page 5

Stationary Capacities–360 Degree
See Operation Note 20

360°

ON TIRES

MAIN BOOM "B"

Load Radius (Ft.)	33 Ft.		40 Ft.		50 Ft.	
	∠ °	Load	∠ °	Load	∠ °	Load
10	66.0	35,900	70.5	35,000		
12	62.0	30,100	67.5	30,500	72.5	30,800
15	55.5	21,500	62.5	22,000	68.5	22,400
20	43.5	12,800	53.5	13,400	62.0	13,900
25	26.5	8,200	43.5	8,800	55.0	9,300
30			31.0	5,900	47.5	6,400
35					38.5	4,400
40					27.0	2,900
Min.Boom Angle/Cap.	0 (27.5)	6,400	0 (34.5)	4,000	0 (44.5)	1,900
Load Radius (Ft.)	50 Ft.			57 Ft.		
	∠ °	Load	∠ °	Load	∠ °	Load
20	67.0	14,000				
25	62.0	9,600	66.5			9,700
30	56.0	6,700	61.5			6,900
35	50.0	4,700	57.0			4,900
40	43.0	3,200	51.5			3,400
45	35.0	2,200	46.0			2,400
Min.Boom Angle/Cap.	30.5 (47.3)		41.5 (48.4)			

⚠ WARNING
Do Not Raise Boom Above 75° Boom Angle.
Loss Of Backward Stability Will Occur Causing a Tipping Condition.

